

MODEL TUT-65RTB

REGISTERING TURNSTILE WITH BUILT-IN TICKET BOX

THE WORLDS MOST RELIABLE ADMISSIONS AND CROWD CONTROL TURNSTILES



HIP/HAND Control Knob
to lock turnstile while
examining tickets

Ticket Box Drop



Promotional or
Ad Space



Optional Platform
With Railing

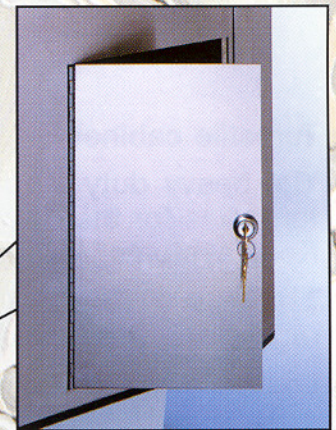

Lockable Ticket
Collection
Compartment
with Canvas Ticket Bag

Optional Wheels
to facilitate moving

TOMSED introduces the first turnstile specially designed for Stadiums, Arenas, Amusement Parks and other ticketing venues. Combines stainless steel construction with a heavy-duty, modular Transit mechanism **and** a ticket collection box into one compact, durable turnstile.

No more falling, dented or lost ticket boxes!



TOMSED® CORPORATION

420 McKinney Parkway, Lillington, N.C. 27546
(910) 814-3800 • Fax (910) 814-3899 • 800-334-5552
email: sales@tomsed.com

VISIT OUR WEBSITE @ www.tomsed.com
SECURITY & TRANSIT CONTROL SYSTEMS



MODEL TUT-65RTB

OPERATION & FEATURES

- The TOMSED Model TUT-65RTB Registering Ticket Box Turnstile is designed to meet the unique needs of Stadiums, Arenas, Amusement Parks, and other Ticketing Venues by combining a Registering Turnstile and a Ticket Collection Box into one self-contained unit.
- The turnstile provides an accurate and reliable count of patron entries using a durable, mechanical counter. Counters can be either non-resettable or resettable.
- The built-in lockable ticket box compartment allows collection and storage of tickets directly in the turnstile, saving valuable space and decreasing cost.
- A hip/hand control enables attendants to temporarily lock the turnstile while examining tickets.
- Turnstile top cover includes a recessed pocket available for promotional or advertising materials.

CONSTRUCTION

- Turnstile cabinet is fabricated from 16 and 14 ga. stainless steel polished to a #4 satin finish.
- The heavy duty modular operating mechanism is identical to those used in TOMSED transit turnstiles for the New York, Boston, Atlanta, Miami, Monterrey, Singapore, Shanghai and Hong Kong systems. All parts are yellow zinc plated to ensure long-lasting, trouble-free performance.
- Standard self-centering feature automatically returns arm assembly to the home position regardless of force used to pass through the turnstile, assuring an accurate count.
- Lockable access doors allow concealed anchoring and maintain a clean, aesthetic appearance.
- Optional platform is fabricated from 5/16" thick steel plate with 1/8" non-skid diamond plate top.

SPECIFICATIONS

Turnstile can have registering entry with a free exit, locked exit or a registering exit.

Height:	38"	Passage Space:	17" Standard	Weight:	100 lbs. NET
Width:	7" Cabinet	Length:	31"		130 lbs. Crated
					+70 lbs. Portable Feature

AVAILABLE OPTIONS

Portable feature including Platform and Railing
Wheels to Facilitate Moving
Second Register to Count Entries

Out of Use Lock
Resettable Counter
Lockable Register Cover



TOMSED® CORPORATION

420 McKinney Parkway, Lillington, N.C. 27546
(910) 814-3800 • Fax (910) 814-3899 • 800-334-5552
email: sales@tomsed.com

VISIT OUR WEBSITE @ www.tomsed.com
SECURITY & TRANSIT CONTROL SYSTEMS



TOMSED CORP

MODEL TUT-65RTB DELUXE REGISTERING TURNSTILE WITH BUILT-IN TICKET BOX

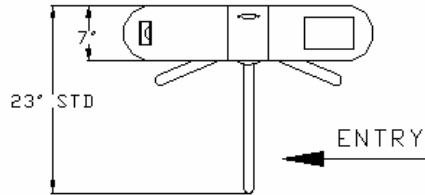

PLAN VIEW

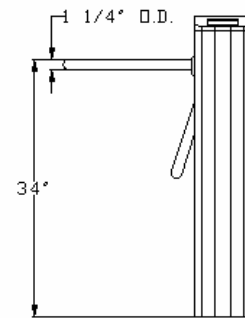
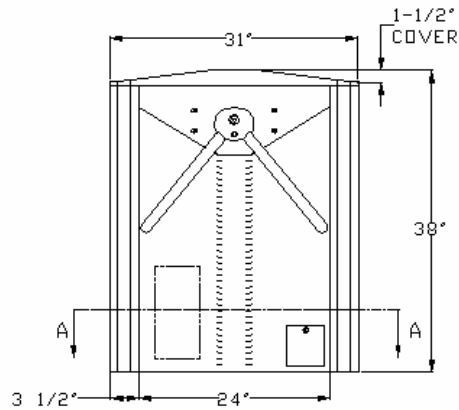

ELEVATION VIEW

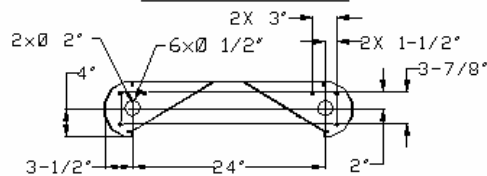

SECTION A-A
FLOOR PLAN

NOTICE:

The data contained herein is proprietary to Tomsed Corp. This data shall not be duplicated, transferred, made available or used by any third party for any purpose except specifically authorized by Tomsed Corp.