

SECTION 32 31 13.15
Chain Link Cantilever Slide Gates

PART 1 GENERAL

1.01 SECTION INCLUDES

- A. Internal roller aluminum cantilever slide gates.

1.02 WARRANTY

- A. Manufacturer shall provide a limited warranty against failure for the gate, rollers and other parts for a period of 7 years. Failure being any manufacturing defect that prohibits normal operation. (see Secure-Trac warranty for more coverage details)

PART 2 PRODUCTS

2.01 MANUFACTURER

- A. Chain link fences, gates, and operators must be obtained from a single source.
B. Approved Manufacturer: Merchants Metals
Phone: (888) 260-1600 Fax: (281) 372-3801

2.02 INTERNAL ROLLER ALUMINUM CANTILEVER SLIDE GATE

- A. Gate Frame: Made in accordance with ASTM F 1184 Type II Class 2, and in compliance with UL-325, and ASTM 2200. (No substitution) Gate to be made of Aluminum Alloy 6005-T61. All square members are 2" sq. weighing 0.94 lb/FT (139 kg/m). Complete frame welded to top (HI-STRENGTH) one piece track and top frame member and 4" x 2" bottom rail weighing 1.71 lbs./ft (2.54 kg/m) Supply 2 truck assemblies that are swivel type having lubricated and scaled ball bearing wheels that have a dynamic load rating of 18,000 lbs. And a 5/8" (16 mm) diameter stainless steel bolts which have a load rating of 11,000 pounds.

Standard Opening	Standard Support Overhang
10'0" (3048 mm)	6'6" (1981 mm)
11'0" (3354 mm) through 14'0" (4267mm)	7'6" (2286 mm)
15'0" (4572 mm) through 22'0" (6706 mm)	10'0" (3048 mm)
23'0" (7010 mm) through 30'0" (9144 mm)	12'0" (3657 mm)
31'0" (9449 mm) through 40'0" (12192 mm)	16'0" (4876 mm)

- Gates 31'0" (9449 mm) thru 40'0" (12192 mm) dual top tracks member weighing 6.36 lb/ft (9.45kg/m). The bottom rail 4" x 2" weighing 1.71 lb/ft (2.54 kg/m). Top tracks require two additional truck assemblies. For gates over 40'0" (12192 mm), contact the manufacturer for custom drawings and specs.

- B. Gate Finish (Frame)
Choose one: Natural Aluminum
or Polymer Coated in color to match fence

- C. Chain Link Filler
Choose one: Galvanized After Weaving
or Aluminized
or Thermally Fused & Bonded PVC

- Available colors - black, green, brown and bronze.
D. Diagonal adjustable 1/4" (6 mm) stainless steel truss cables (2) provided inside each panel of the gate. (One each direction).
E. Gate posts are 4" O.D. (101.6 mm) schedule 40 weighing 9.11 lb/ft (13.6 kg/m).
Single gates with single tracks require 3 gate posts. (1 latch post and 2 support posts)
Single gates with dual tracks require 5 gate posts. (1 latch and 2 dual support posts)
Double gates require twice the number of support posts but do not have a latch post.

PART 3 EXECUTION

3.01 GATE INSTALLATION

- A. Set posts in concrete. Dig holes having a diameter 4 times the diameter of the post, and 6" (152 mm) deeper than the bottom of the post. Posts set a minimum depth of 36" (914 mm) for all cantilever gates.



Additional Fence Solutions

Merchants Metals is one of the largest manufacturers and distributors of fence systems in the nation. The company's complete line of fencing solutions for residential, commercial and industrial applications includes:

- Hot Dipped Galvanized Chain Link
- Color Coated Chain Link
- Steel Ornamental in Both Component and Fully-Welded Systems
- Aluminum Ornamental Systems
- Wood Fence
- PVC Fence
- Temporary Fence
- Aluminum Track Gates
- Access Control Products
- Guardrail
- Pre-hung Security Gates

All Merchants Metals products are available through professional fence contractors nationwide.

To find out more about Merchants Metals and the fencing solutions we offer, please call 866.888.5611 or visit www.merchantsmetals.com.

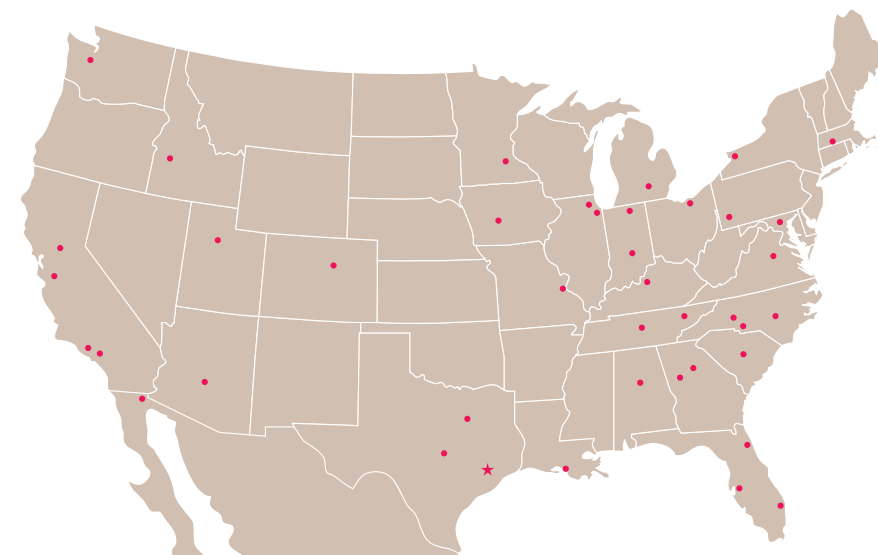

AIA Continuing Education



ORNAMENTAL



CHAIN LINK



WOOD



PVC



ACCESS CONTROL



info@merchantsmetals.com
866.888.5611
www.merchantsmetals.com
a division of MMI Products, Inc.



Secure-Trac®

Internal Roller
Cantilever Slide
Gates





Secure-Trac® Cantilever Slide Gates combine the highest quality materials and workmanship to ensure years of maintenance free service. The use of high alloy aluminum results in superior strength with reduced weight compared to other gates and the enclosed roller system eliminates the safety issues associated with external rollers.

All welded construction ensures a rigid assembly. The easy opening full cantilever design works well with electric or hydraulic gate operator systems, and the enclosed roller system is virtually unaffected by ice, snow, dirt or other debris.



Every Secure-Trac® Internal Roller Cantilever Slide Gate can be electrically or manually operated.



Premium Rigid Frame Construction

Internal Roller Track: The backbone of our Secure-Trac® gate, the internal roller track is a one piece extrusion consisting of the track and the top 2" square frame member. This one piece design is welded as part of the gate frame, adding needed strength and rigidity, as opposed to gates with "bolt-on" tracks.

Uprights: The upright members, which are also 2" square, are welded to the internal roller track. The uprights are evenly spaced along the length of the gate frame and are never more than 8'0" apart.

Bottom Frame Members: The bottom member of the gate frame is a 2" x 4" rectangular tube which is welded to the 2" upright members, forming a rigid one piece frame and track.

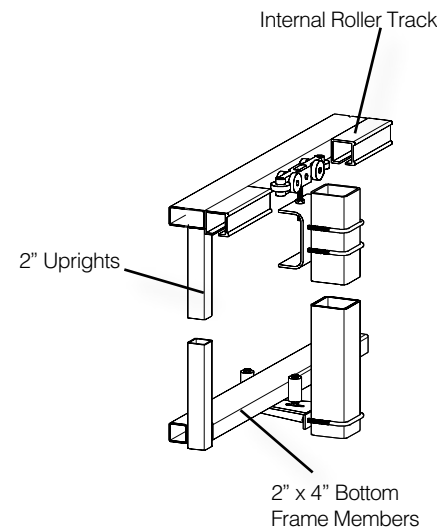

Secure-Trac® Gates Size Adjustments

Secure-Trac® gates can be built to accommodate a wide range of openings. Single gates accommodate 10' – 40' openings and double gates accommodate 20' – 80' openings. (Any single gate more than 30' wide will have two internal tracks.)

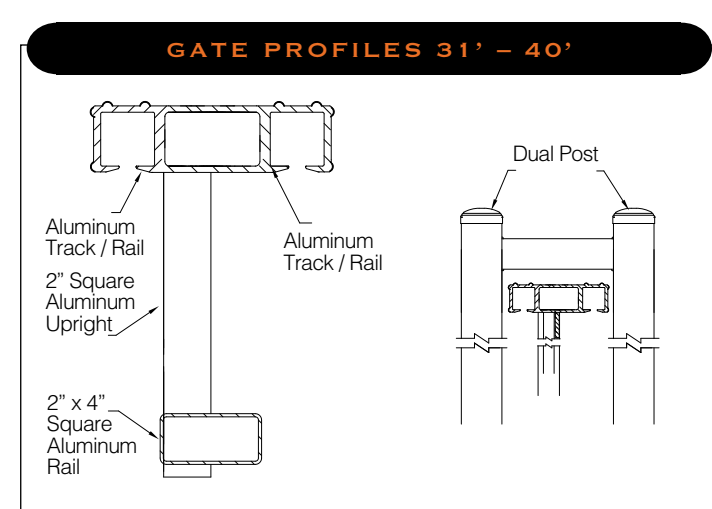
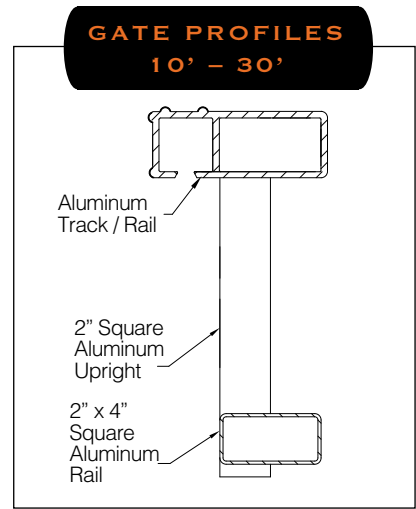
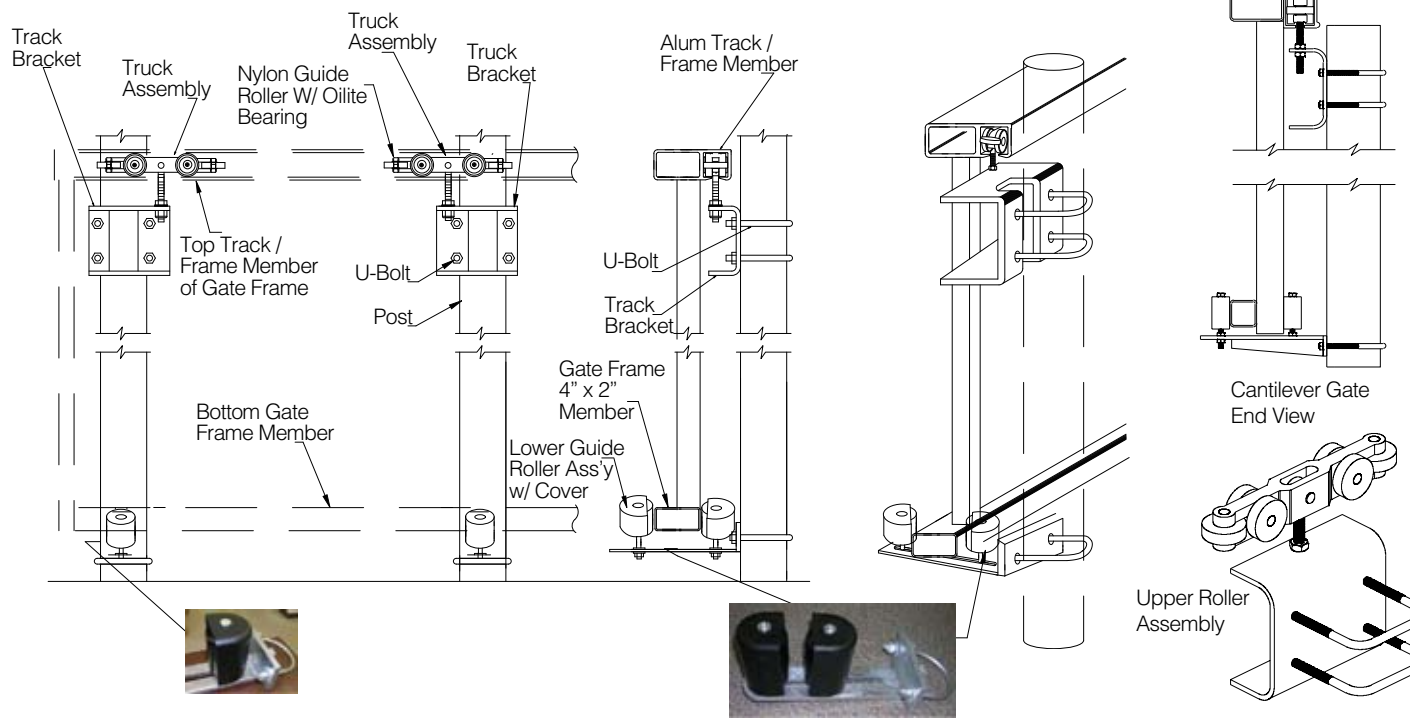

Top Roller Assembly

Inside the track channel is a truck assembly. Both the track and the truck assembly are designed to withstand a reaction load in excess of 2000 lbs. The truck bracket assembly is lubricated prior to production to enhance performance and endurance. (Fig. A)

The Secure-Trac® truck assembly has a swivel bolt that allows rotation in all directions. This assures even wear of the wheels and less wear and tear on the gate and the electric operators. (Fig. B)

The Secure-Trac® truck assembly is made to swivel up or down, as well as side to side, to accommodate the movement of the gate frame. (Fig. C)

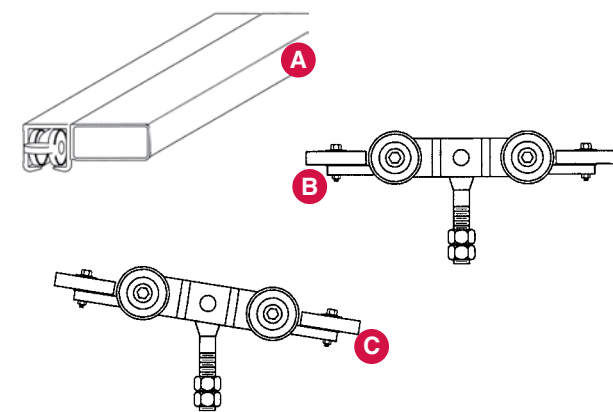

Secure-Trac® Gates are available with picket or chain link fillers

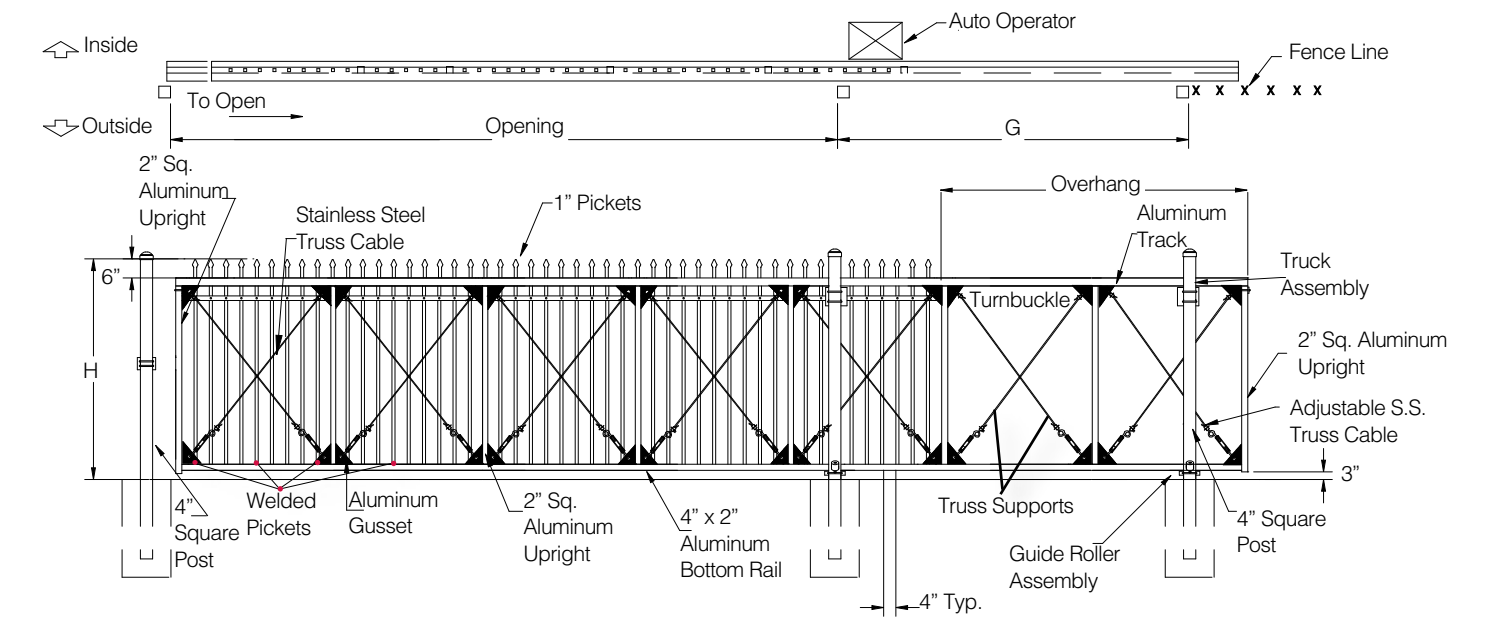

With ornamental picket gates (pointed picket style shown above), all pickets are welded between upper and lower frame members, increasing support and rigidity to the overall gate frame.

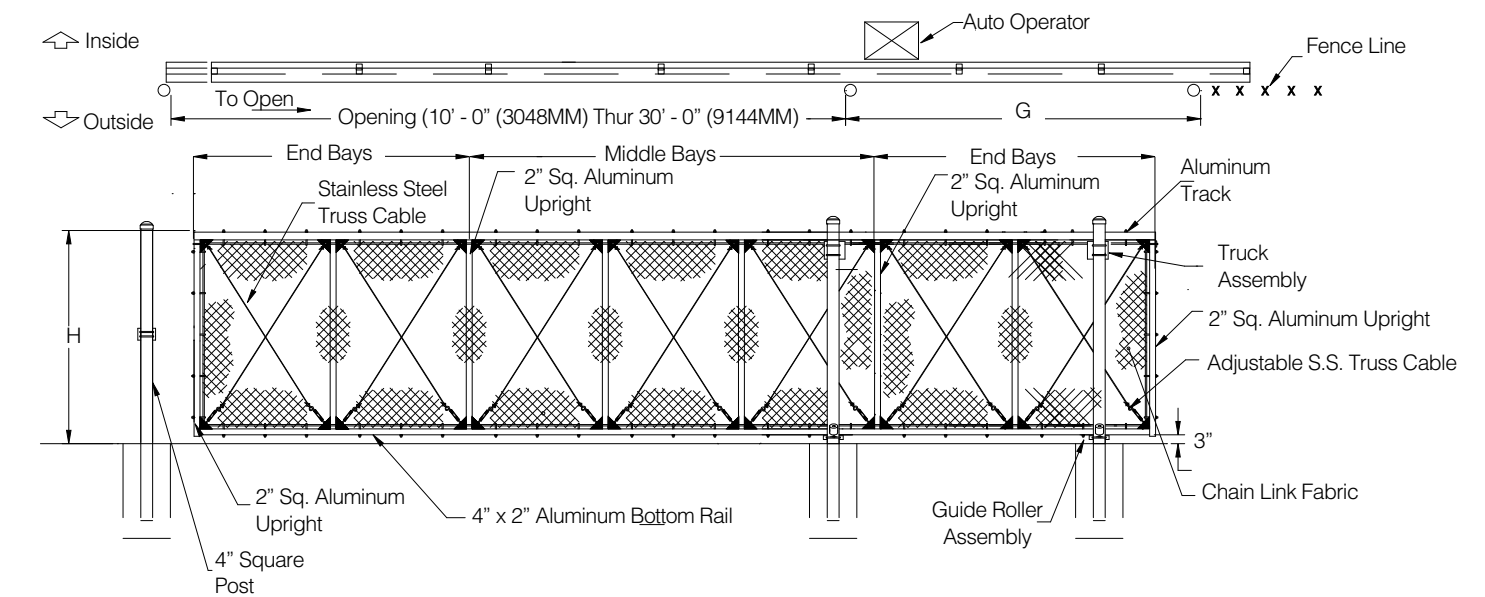

With chain link Secure-Trac gates®, the chain link fabric is factory installed. We stretch the fabric in four directions so that each strand of wire acts as a truss increasing support to the frame. Some manufacturers only stretch their fabric in one direction ultimately working against the frame by merely adding weight.

Welded Gussets and Truss Cables

For optimum frame rigidity, each interior panel is equipped with four welded gussets and a pair of stainless steel adjustable truss cables. This added support is standard on both ornamental and chain link gates.